



**FRIEDERICHS**  
**GERMANY**







# FRIEDERICHS

## GERMANY

### TABLE OF CONTENTS

04	Introduction
06	Company history
07	Timeline
08	Corporate philosophy
10	Production and quality management

#### PRODUCT GROUPS

12	Armored cars
14	Cash and valuable transporters
16	Judiciary vehicles
18	Ambulances   Rescue
20	Emergency vehicles
22	Mobile special vehicles   Vehicle construction
30	Logistics and after-sales service



A company history of more than 175 years makes Carl Friederichs GmbH one of the most well-established companies in Germany. We offer our customers modern bodies that are based on state-of-the-art technical development. From carriage construction and the first motor vehicles in the past to special superstructures and extensions today – we have always developed solutions for individual requests of all kinds.

Our work focuses on customer-oriented thinking and action and allows us to be up to date due to efficient management and qualified employees, to strengthen our position in the market as an economically sound and successful company as well as to pave the way to the future by our own efforts.

Our high standards in terms of product quality represent one of the company's most important pillars. These standards are met through our own quality management which is certified according to DIN ISO 9001.

Our range of services includes individual solutions for special vehicles that meet their challenges as well as maintenance works and painting of cars and trucks of all manufacturers at our repair department.

Due to our precision and expertise we are able to develop and deliver special vehicles at the highest level on a global scale. This is highly appreciated by our national and international customers.

Carl Friederichs GmbH offers high standards in the field of security technology and aims at providing its customers with cutting-edge technology at all times. We will continue to focus on the performance and safeguarding of the highest technical standard in the future. We stand by your side!

Yours Henrik Schepler,  
CEO

Yours Stephan Berger,  
CEO



*Heinz Friederichs,  
founder of the "Heinz und Gisela  
Friederichs Stiftung"*



*Gisela Friederichs  
founder of the "Heinz und Gisela  
Friederichs Stiftung"*



## July 1st 1840

Carl Friederichs GmbH is a vehicle construction and bodywork company as well as a manufacturer of special vehicles. “Carl Friederichs” is the brand name of an independent German manufacturer for special vehicles that was originally founded as a carriage construction company by Heinrich Ludwig Friederichs in Frankfurt am Main on July 1st 1840.

In the beginning he was a restless spirit, driven by the ambition to accomplish something extraordinary and to create masterpieces of craftsmanship. Heinrich Ludwig Friederichs started his journey as a young man with the aim of manifesting and expanding his knowledge. Naturally, there was no better city to travel to than London which was thriving as a trading empire. Drawings and certificates prove that Heinrich Ludwig Friederichs quickly internalized the British employers’ mastership. At the time, several brands offered basic equipment with a need for finishing and luxury equipment. Individual design was as important to the dandies as it is to us now. Friederichs continued his journey to the tsar’s court in St. Petersburg, Russia, to augment his knowledge and to get familiar with more foreign influences. After a longer period of captivity and social unrest he traveled back to Frankfurt in 1838.

Heinrich Ludwig Friederichs had gained a lot of impressions and even more expertise through his travels and finally achieved his aim: He founded his own saddlery and bodywork company in Frankfurt in 1840. But those who believe it was a simple workshop are mistaken. Due to the extensive experience he gained abroad, Heinrich Ludwig Friederichs could offer more than just simple repair works and his company soon became one of the first and finest bodywork manufactures in his day.

Individual body construction was thriving as traditions were passed on from father to son and expertise was gained through experience and by focusing on technical progress. But there was a sudden change when Henry Ford introduced assembly line production. However, it did not do any harm to the company which developed into a big and renowned business, especially during the years of the economic miracle. 5,000 square meters of factory workshops and a huge coating area were equipped with state-of-the-art technology. The company focuses more and more on the construction of individual special vehicles. Friederichs’s special bodies have made today’s economy a lot more mobile and economic.

By now, the company can be considered a specialist in the construction of cash transporters and workshop vans but laboratory trucks and civil armored cross-country vehicles are also part of the company’s large and successful portfolio. The “Heinz and Gisela Friederichs Stiftung” is the sole shareholder and supervises the company’s philosophy and continuous development. The business continues to grow and more than 110 employees work in two business areas – repair works/coating of damaged vehicles and manufacturing of special vehicles of all kinds – for a worldwide customer base.



# Tradition MEETS THE FUTURE



**1840** Founding of the company as a saddlery and body works company by Heinrich Ludwig Friederichs.

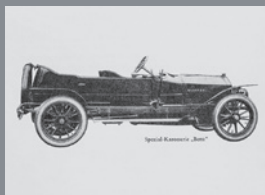

**1840** Founding of the company as a saddlery and body works company by Heinrich Ludwig Friederichs.

**1876** Carl Friederichs's son takes over the business. Transition from the construction of horse-drawn carriages to the construction of motor vehicles.

**1900** Sons Heinrich and Rudolf Friederichs take over the company. Construction of automobile bodies for vehicles like Maybach, Benz, Mercedes, Packard, Horch, etc. Patent for cabriolet bodywork.



**1944** Destruction of the permanent establishment due to an air raid.

**1946** Restart and new construction in Gutleutstraße. Rudolf Friederichs's son Heinz takes over the company's management.

**1953** Move to Hardenbergstraße due to business expansion.



**1964** Opening of a second business in Schlitzer Straße: construction of commercial vehicles of all kinds for Europe, the Orient and Africa.

**1991** Heinz Friederichs and his wife establish the "Heinz und Gisela Friederichs Stiftung" shortly before his death. The foundation is dedicated to social projects which promote the vocational training of young people in the bodywork and vehicle construction sector as well as to contemporary art. It is also the sole shareholder of Carl Friederichs GmbH.



**2003** Construction of a modern brake test stand and calibrated vehicle scale.

**2004** Extension of the workshops at Schlitzer Straße through the construction of a large new coating center.

**2006** Additional halls for the construction of vehicles and bodies are built at Schlitzer Straße.



**2016** Carl Friederichs GmbH is one of the leading vehicle and bodywork companies in Germany and worldwide. It combines two business areas: construction of special vehicles and repair works/coating. Carl Friederichs GmbH's special bodies are used around the globe as cash transporters, ambulances, police vehicles, etc. At a local level, the company is one of the top addresses in terms of repair works and coating of vehicles as it features one of the biggest and most modern coating centers in the Rhine-Main area. More than 110 employees – including 20 trainees – work at the company's two sites in Frankfurt.

## OUR CORPORATE PHILOSOPHY

Carl Friederichs GmbH combines all ideals and advantages of a grown and tradition-steeped family business with high-quality German engineering work in order to guarantee your safety. Our company has pursued the same guiding principle for years:

*“Our customers’ satisfaction and safety are always our number one priority!”*

We highly trust in our expertise in order to pursue this guiding principle! We meet the challenge to implement your individual demands and take on full responsibility for your safety and the safety of your products and goods. This is what our name and reputation stand for!

Safety requires a lot of expertise. We want to fully meet the demands and purpose of each project so that we can develop a safe and individual solution for every request. We are not afraid of pioneering as it is part of our work in order to satisfy our customers and to achieve the best results.

Companies like Friederichs are not based on the work of a single person. Their strength depends on the skills and dedication of all employees. As advanced as modern technology might be: Body construction remains individual mental and manual work. Intellectual activity is one of the biggest virtues in vehicle construction. The pride of craftsmanship and the ambition to always do your best – that is why Friederichs’s bodywork and vehicle construction has been successful for more than 175 years.

The use and further development of state-of-the-art technology will remain our number one priority in the future because your safety is our task which we want to continue to perform with great passion.

Our service starts with your idea, your demand and our challenge to ensure a precise implementation of it. Our work continues after the completion of your order. We are there to support you as a reliable partner in terms of security matters.

Ideas outlive people. Ambitions develop their own dynamics. They shape a company over centuries. If you talk to the experts at Friederichs today you’ll quickly realize that the company founder’s innovative spirit is still alive in the present!







## PRODUCTION AND QUALITY MANAGEMENT

Friederichs can assure you of one thing: Only highly qualified personnel will take care of your car, using the latest technology! Everything starts with the chassis. But only vehicle construction can turn it into a versatile and supporting means of transport that carries heavy load.

Flexibility, a close collaboration with our customers and technical knowledge allow us to specify your special demands and to implement your individual requests.

The construction of armored cars starts with the chassis. Ballistic steel components are integrated in the vehicles through precise laser cuts to create the special protection cell. The passengers are now protected against possible projectiles. Additional ballistic composites are applied during the process if possible and needed.

The reassembly of the vehicle is a complex process and marks the next step. Depending on the size of the car's interior, the car is completely equipped with durable padding. Thereafter, bullet-proof glass is fitted in the frames. Specially shaped door panels, reinforced hinges, enhanced brakes, heavy load stabilizers, coils, emergency batteries, run-flat tires and window regulators are part of the standard equipment!

### Friederichs is certified according to DIN ISO 9001!

In order to successfully fulfill our customers' wishes at the highest level it is essential to check and enhance our performances and production processes regularly.

The continuous application of our quality management system makes a transparent documentation of our performances possible. We do not want to rest on our laurels but improve constantly.

Apart from internal and external supervisory bodies, our customers' trust sets the benchmark.

*If you are permanently satisfied and gladly recommend us – that's quality!*

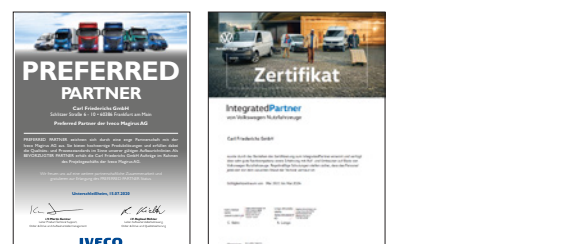
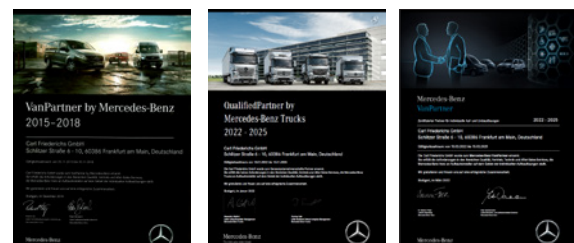







ARMORED CARS



## CASH AND VALUABLE TRANSPORTERS

### INFOBOX

- Cash and valuable transporters
- Protection of money printing plates
- Protection of hazardous substances
- Run-flat tires
- Bulletproof tank

Many years of know-how and a close collaboration with our customers allow us to always combine technical feasibility and a suitable vehicle concept in accordance with the customer's requirements. You may rest assured: Our technical department draws up a detailed, three-dimensional plan on the computer prior to start of construction of each vehicle. In this way, a critical first impression of the overall project and its individual construction phases can be provided.

A qualified team of motivated and specially trained employees combines traditional body construction and modern manufacturing processes. Each vehicle is the result of individual construction. We collaborate closely with public audit authorities like the German firearms proof house and selected, certified cooperation partners for the respective set of panes or special steel used to ensure highest value and durability of our armored cars and to protect everything you want to transport.

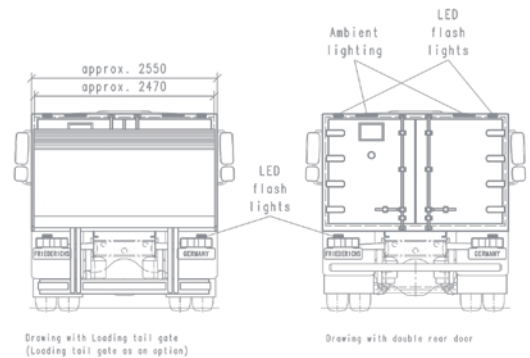
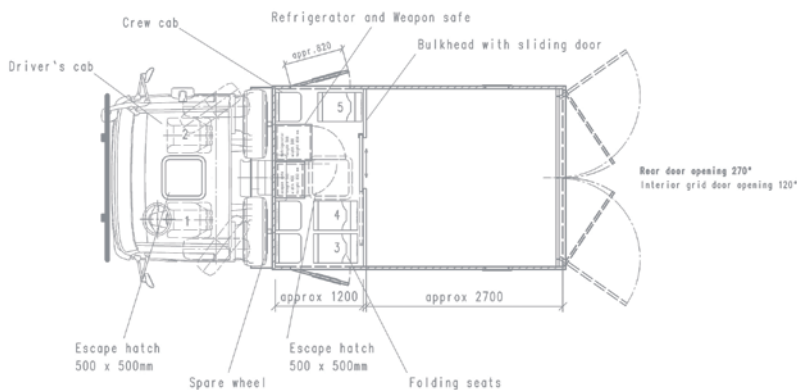
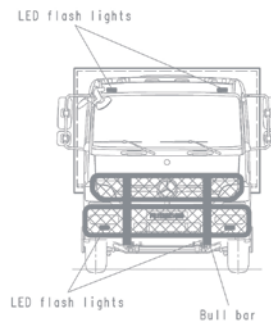
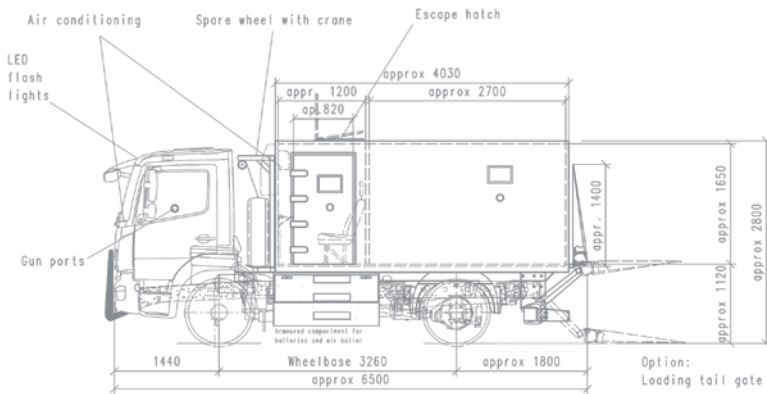



CASH AND VALUABLE TRANSPORTERS



## JUDICIARY VEHICLES

### POLICE

- Checkpoint vehicles
- Personnel carriers
- Forensics vehicles
- Emergency vehicles
- Water guns

### JUDICIARY

- Prisoner van – small
- Prisoner van – medium
- Prisoner bus

To us, vehicles for prisoner transport represent a special highlight in the field of vehicle development. Products of various vehicle manufacturers – e.g. vans or buses – have full factory warranty after conversion and will surely play an essential role within your vehicle fleet.

Every vehicle designed by our company is subject to the applicable standards, rules and laws. All our vehicles are planned prior to start of construction in close collaboration with the customer. A technical acceptance documents the progress of the conversion process.

We want to adapt judiciary vehicles to the conditions of a rough daily routine and difficult situations in order to use it as a secure means of transport. We guarantee that we carefully select the materials used and we are proud to be able to offer this kind of special vehicle as part of our company's portfolio.







JUDICIARY VEHICLES



## AMBULANCES | RESCUE

### INFOBOX

- Ambulances
- Emergency vehicles
- Certified equipment
- Special protection possible
- Rescue vehicles based on truck 6x6

Our ambulances and emergency vehicles are not manufactured in series production. Each vehicle with its respective equipment is unique. As with all other types of vehicles, we like to meet challenges and one of our priorities is to take the vehicle's purpose of use into consideration during construction. Our vehicles are equipped exclusively with renowned, certified and high-quality equipment. We already have some interesting references in this field.

In one case, we camouflaged an ambulance as a minibus and equipped it with special protection upon request of a customer. In another case, we equipped a 6x6 truck with special equipment in order to use this vehicle for the rescue of buried people, after severe road accidents and for civil protection.





AMBULANCES | RESCUE



## INFOBOX

- Civil protection vehicles
- Decommissioning vehicles
- Flatbed superstructures/with crane
- Command vehicles
- Personnel carriers
- Mobile workshops

## EMERGENCY VEHICLES

We have been working closely with German authorities and/or institutions for years, we focus on the details, analyze all of the vehicle's requirements and systematically select our suppliers – all these aspects strongly characterize Carl Friederichs GmbH's emergency vehicles.

No matter if used by the police, fire department or emergency response teams: All our vehicles and their integrated vehicle system have met their operators' requirements and demands and have proven successful over the years. The systems are continuously adapted to cutting-edge technologies and give a personal note to the emergency vehicles so you can fully rely on your vehicle, concentrate on the respective situation and be able to assist.





## MOBILE SPECIAL VEHICLES I VEHICLE CONSTRUCTION

### INFOBOX

- Mobile workshops
- Mobile banks
  - Security for the bank's employees
  - Personal and comfortable flair for clients

Another part of our product range focuses on the construction and finishing of special vehicles. Numerous interesting projects have been developed in the course of time.

**We would like to describe seven vehicle types in detail by way of example:**

- 1) A fully equipped mobile bank including all necessary security measures for the safekeeping and transport of cash as well as an ATM and several compartments for confidential customer service.
- 2) A mobile, fully equipped workshop so that vehicles and machines can be maintained and repaired worldwide, even in remote places.



1) mobile banks





2) mobile workshops

## MOBILE SPECIAL VEHICLES I VEHICLE CONSTRUCTION

- 3) Equipment vehicle for emergency services
- 4) Vehicle for aircraft warning lights services: A fully equipped and lowerable vehicle with a work area that is freely accessible due to a manual floor opening. Service works can be performed on Frankfurt airport's apron – independent of wind and weather and without having to leave the vehicle.
- 5) Fitness Truck: Carl Friederichs GmbH's mobile gym. A converted MB Sprinter is located directly on the airport apron so that the airport staff can work out at any time. This unusual workout possibility helps the employees to maintain their physical fitness and creates a balance to everyday life on the apron. The airport operator was awarded the Human Resources Excellence Award for this concept.
- 6) Armored guard houses
- 7) Protection vehicle for highways



3) Equipment vehicle for emergency services





MOBILE SPECIAL VEHICLES



4) Vehicle for aircraft warning lights services





5) Fitness Truck

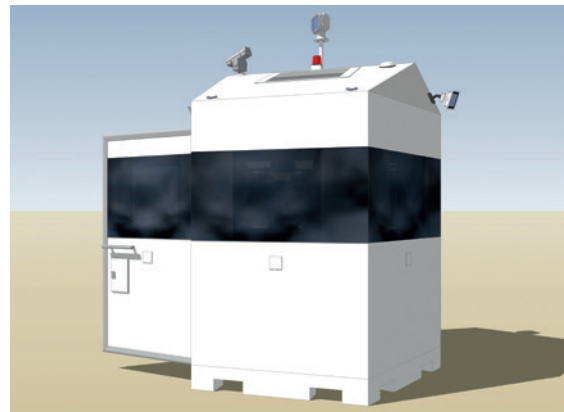

6) Armored guard houses



7) Protection vehicles for highways



Fire department – personnel carrier for special operations



Police – command vehicle



Armored escort vehicle



Armored cash transporter

## LOGISTICS AND AFTER-SALES-SERVICE

It is of great importance to us to extensively support our customers at all times after the products have been completed. We offer many after-sales services for all kinds of vehicles because we know that our customers rely on them. This is why we'd like to offer our support if you are looking for spare parts or need help with their delivery. Our specialists are always available worldwide to repair your vehicles.

Of course, our technicians are able to work in different workshops anywhere in the world in order to efficiently perform the repair works needed to make your vehicle ready for use again as soon as possible.

Naturally, after having manufactured a product, we want it to be handed over to our customers without any problems. All products can be picked up on site but as a matter of course we also deliver to agreed addresses worldwide.

Carl Friederichs GmbH takes care of all freight services like land, sea or air freight. Certainly, we organize and coordinate all documents and paperwork to ensure smooth operations.





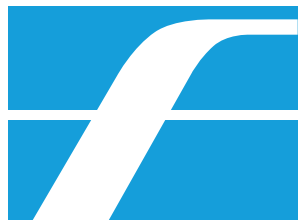

# FRIEDERICHS

## GERMANY



**CARL FRIEDERICHS GMBH**

Schlitzer Straße 10, 60386 Frankfurt am Main

Phone: +49 69 9410041, Telefax: +49 69 9410046703

Mail: [kontakt@cf-frankfurt.de](mailto:kontakt@cf-frankfurt.de)

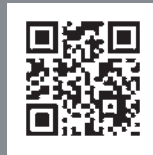

[www.cf-frankfurt.de](http://www.cf-frankfurt.de)



[facebook.com](https://www.facebook.com)



You **Tube**



[youtube.com](https://www.youtube.com)